

IMS.80 Pro LN

Solutions that don't let you down!

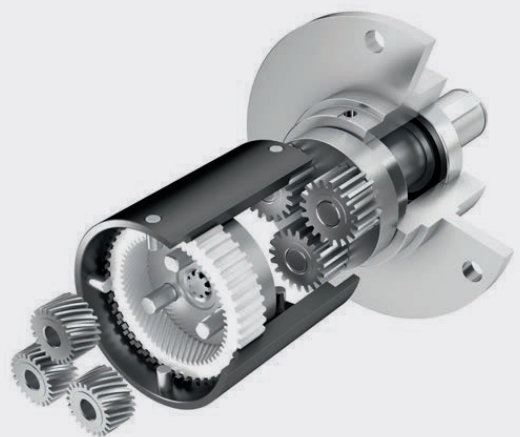



Logistics / Fork-lift Trucks

Planetary gears from IMS Gear

For many years, planetary gears from IMS Gear have become indispensable in the field of **industrial intralogistics**. With our IMS.Drive series we have developed a product series that is custom-fit for the special requirements of fork-lift trucks, but also for AGVs (Autonomous Guided Vehicles) or AMRs (Autonomous Mobile Robots). Lifting loads and the spirits!

- High efficiency
- Small installation space
- Low noise development

With its modular system, IMS Gear's spectrum ranges from quick quality solutions to customer-specific adaptations and sophisticated special gear configurations. The same applies to our solutions for intralogistics.

Being able to react to changing requirements quickly and efficiently - this is IMS Gear.

Intralogistics with IMS Gear

For years, almost noiseless fork-lift trucks in huge industrial warehouses have used planetary gears from IMS Gear as the power transmitting element of **electromechanical steering systems**. The solutions are centered around the configuration of proven elements of the modular system from

different product lines that have established a product line of their own: the special IMS.Drive series. The result far exceeds the limits of the modular system and meets **increased requirements to torque, low noise, and installation space** without the need for special development.

Safe and Silent Steering

For almost two decades, leading manufacturers of industrial trucks have trusted in planetary gears from IMS Gear for **safe and silent steering systems**. The ability to reliably transmit **high forces in small spaces** makes our planetary gears ideally suited for this application. Originally, IMS Gear

met the user-specific requirements, e.g. to the available installation space or the required torque strength, by two gear variants with different diameters.

New Conditions - New Solutions

Even so, improvements of the application were continuously implemented with recourse to the modular system. "In 2001, it was all about reducing the noise level", Sales Engineer Andreas Sigwart illustrates the further development. This had been triggered by a modification of the industrial truck drives, in particular with fork-lift trucks: Instead of combustion engines with diesel or gas drives and the respective noise development, **battery-electric drives** that operate emission-free and almost silent have prevailed.

The new development of a planetary gear optimized for low noise would have taken a lot of time, involved high expenses, and entailed respective technological risks. Thanks to the use of a helically geared input stage from the IMS Gear modular system especially designed for **low noise applications**, this effort could be avoided.

New Paths Beyond the Modular System

After the helically geared solution had reliably fulfilled its service for more than 10 years, yet another adaptation to further increased requirements became necessary.

To be precise, the achievements consisted in **higher torques, an increased robustness against overload torques, a longer service life and a further improved noise behavior.** "All this had to be realized with reduced installation space in order to be able to serve as many different steering systems as possible", Sigwart reports.

IMS Gear resorted to its box of tricks: The combination of different series within one gear drive, complemented by new specific gear components, was a new approach beyond the modular system.

The helically geared input stage from the IMS.81 Pro LN ensures smooth running. For this application, the bearing bolts of the planetary carriers are flattened on both sides. This results in a lubricating groove that significantly extends the service life of the gear drive. Instead of an axial screw connection with a housing diameter of 105 mm, IMS Gear uses a new one-piece radially reduced housing with a diameter of

80 mm. Apart from the space saving the bearing flange is omitted as it can now be integrated.

The gear drive and motor are assembled without screws; instead, the gear housing and the motor are attached by a **radial pin connection**. This type of connection prevents the twisting of the motor against the gear drive - even more important with higher torques. In the first stage, a special helically-geared insert is installed as ring gear. At the outside, the gearing of the insert engages positively into the housing gearing of the second stage and so prevents the twisting. In the output stage, planetary wheels of size IMS.105 Pro transmit the high torques and can briefly absorb dynamic peak loads. These planetary wheels have proven themselves in many projects with **high load requirements** in the power steering of fork-lift trucks. At the individually designable output side, we from IMS Gear routinely use ball bearings and output shafts from the IMS.120 Pro series. These two components resist the high radial forces at the output side that may occur if a wheel of the fork-lift truck incidentally hits a curb.



Summary

To meet the specific requirements in the area of fork-lift and industrial trucks at any time, we from IMS Gear have always smartly refined our solutions. It is based on a reliable set of proven planetary gear series, complemented by our well-known advisory and development expertise that we demonstrate again and again by thoroughly analyzing the special requirements of our customers. The result provides for the safe, reliable, and silent transportation of goods at many places around the world.

empower solutions : worldwide

+49 (0)771 8507-38126

sergej.merger(at)imgear.com

www.imgear.com